

PmGnssComNavK801

This Pmod™ compatible module contains the ComNav SinoGNSS K801 GNSS receiver. The receiver has different possibilities to get accessed. An UART and I2C interface as well as a PPS are available on the Pmod™ connector. In addition, it offers a direct access via a USB. This connection can be used to configure the module via the u-center. The module can be battery backed which allows to maintain known GNSS information.

Key Features:

- ComNav K801 standard precision GNSS module
- Different interfaces to access the module (UART, I2C or USB)
- UART, I2C, Pulse Per Second (PPS) and a Reset are available on the Pmod™ connector
- Passive or active antenna
- PPS indication on LED
- Compatible NetTimeLogic IP-Cores: TOD Slave, PPS Slave Adjustable Clock

Module:

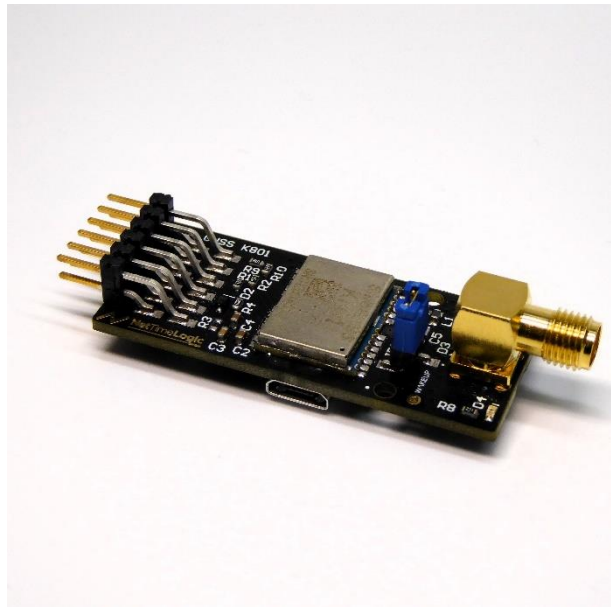

Block Diagram:

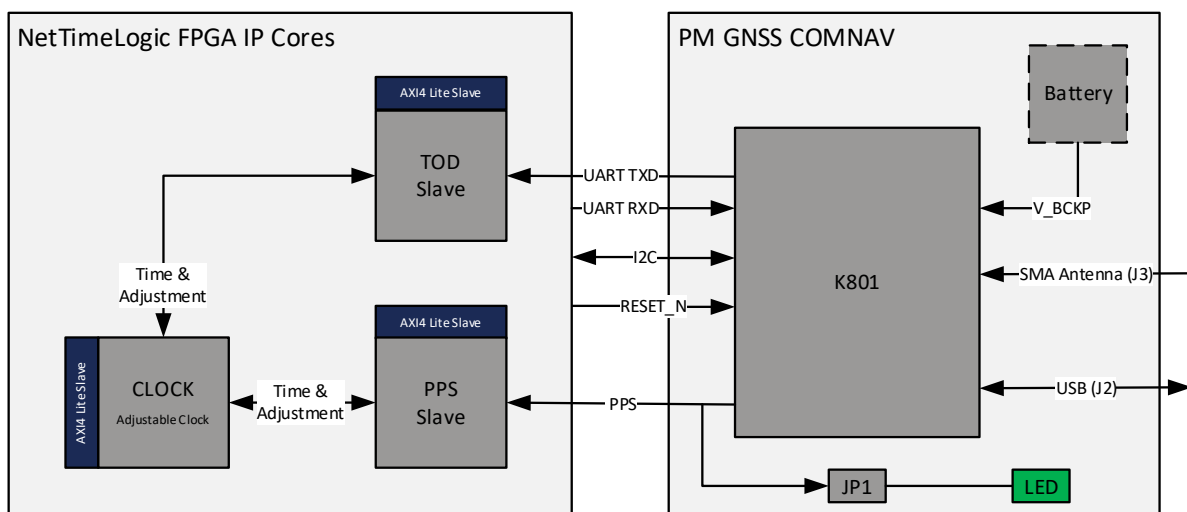

Specification:

GNSS Module	ComNav K801 module
UART	3V3 TTL UART with configurable baudrate (default 38400 baud, 8 bits, no parity bit, 1 stop bit)
I2C	I2C line on 3V3 with pull-ups on the board (Address: 0x42)
Config	Jumper (JP1) placed → PPS on D4 visualized
Battery	CR1026
Power	~100mA @ 3.3V (dep. on conditions with passive antenna)
Output	max. 200mA @ ~3.2V on J3 for an active antenna

Pmod™ Pins and Module Overview:

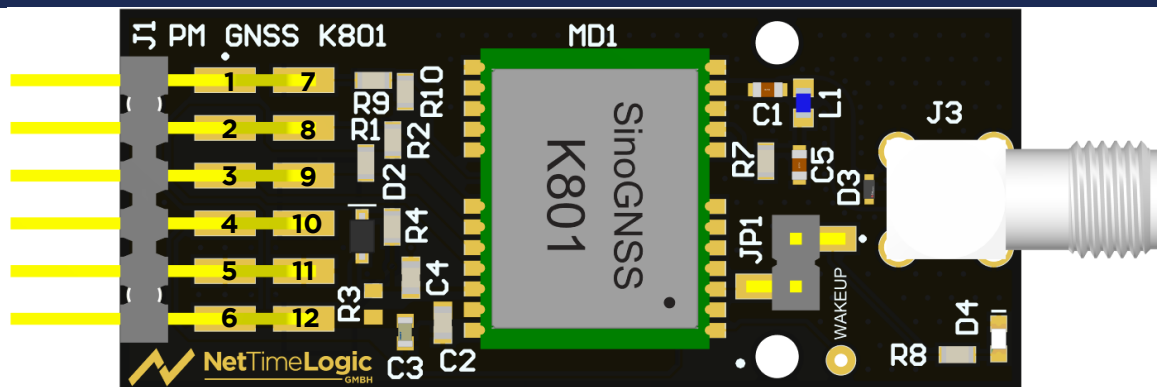

Pin	Signal	Direction	Description
Header J1 (Pmod™)			
1	NC	-	Not connected
2	RXD	In	RXD Pin of the K801 (Pin 21)
3	TXD	Out	TXD Pin of the K801 (Pin 20)
4	PPS OUT	Out	PPS output from the PPS Pin of the K801 (Pin 3)
5	GND		GND connection to the carrier board
6	VCC		3.3V supply from the carrier board
7	RESET_N	In	RESET_N to the RESET Pin of the K801 (Pin 8)
8	SDA	In/Out	SDA Pin of the K801 with 4.7 kOhm Pull-Up (Pin 18)
9	SCL	In/Out	SCL Pin of the K801 with 4.7 kOhm Pull-Up (Pin 19)
10	NC	-	Not connected
11	GND		GND connection to the carrier board
12	VCC		3.3V supply from the carrier board
SMA			
J3	Antenna	In	Antenna connector for active or passive antennas
USB			
J2	USB Con	In/Out	Micro-USB connector to access the module directly e.g. via u-center