IrigMasterClock

Reference Manual

Product Info	
Product Manager	Sven Meier
Author(s)	Sven Meier
Reviewer(s)	-
Version	1.5
Date	28.01.2023

Copyright Notice

Copyright © 2025 NetTimeLogic GmbH, Switzerland. All rights reserved.

Unauthorized duplication of this document, in whole or in part, by any means, is prohibited without the prior written permission of NetTimeLogic GmbH, Switzerland.

All referenced registered marks and trademarks are the property of their respective owners

Disclaimer

The information available to you in this document/code may contain errors and is subject to periods of interruption. While NetTimeLogic GmbH does its best to maintain the information it offers in the document/code, it cannot be held responsible for any errors, defects, lost profits, or other consequential damages arising from the use of this document/code.

NETTIMELOGIC GMBH PROVIDES THE INFORMATION, SERVICES AND PRODUCTS AVAILABLE IN THIS DOCUMENT/CODE "AS IS," WITH NO WARRANTIES WHATSOEVER. ALL EXPRESS WARRANTIES AND ALL IMPLIED WARRANTIES, INCLUDING WARRANTIES OF MERCHANTABILITY AND FITNESS FOR A PARTICULAR PURPOSE, AND NON-INFRINGEMENT OF PROPRIETARY RIGHTS ARE HEREBY DISCLAIMED TO THE FULLEST EXTENT PERMITTED BY LAW. IN NO EVENT SHALL NETTIMELOGIC GMBH BE LIABLE FOR ANY DIRECT, INDIRECT, INCIDENTAL, CONSEQUENTIAL, SPECIAL AND EXEMPLARY DAMAGES, OR ANY DAMAGES WHATSOEVER, ARISING FROM THE USE OR PERFORMANCE OF THIS DOCUMENT/CODE OR FROM ANY INFORMATION, SERVICES OR PRODUCTS PROVIDED THROUGH THIS DOCUMENT/CODE, EVEN IF NETTIMELOGIC GMBH HAS BEEN ADVISED OF THE POSSIBILITY OF SUCH DAMAGES.

IF YOU ARE DISSATISFIED WITH THIS DOCUMENT/CODE, OR ANY PORTION THEREOF, YOUR EXCLUSIVE REMEDY SHALL BE TO CEASE USING THE DOCUMENT/CODE.

Overview

NetTimeLogic's IRIG Master Clock is a full hardware (FPGA) only implementation of a synchronization core able to synchronize other nodes to an IRIG-B/IRIG-G output. The whole algorithms and calculations are implemented in the core, no CPU is required. This allows running IRIG synchronization completely independent and standalone from the user application. The core can be configured either by signals or by an AXI4Lite-Slave Register interface.

Key Features:

- IRIG-B and IRIG-G Master Clock
- Supports IRIG-B007 and IRIG-G006 format (compatible with B004, B005, B006 and B007 IRIG-B Slaves)
- Optionally supports IRIG-B127 and IRIG-G146 format (compatible with B124, B125, B126 and B127 IRIG-B Slaves) with AM encoded AC (requires a DAC)
- Optional support all IRIG-Bxx0 - Bxx7 codes, changeable at runtime
- Optional support Control Bits for IRIG-Bxx0/Bxx1/Bxx4/Bxx5
- PWM, DCLS encoding
- Output delay compensation
- Additional seconds correction to convert between TAI and UTC time (or any other time base)
- AXI4Lite register set or static configuration
- IRIG resolution with 50 MHz system clock: 20ns (DCLS)

Revision History

This table shows the revision history of this document.

Version	Date	Revision
0.1	20.10.2015	First draft
1.0	28.10.2016	First release
1.1	20.12.2017	Status interface added
1.2	25.06.2018	IRIG mode and control bits added
1.3	16.02.2022	IRIG-G added
1.4	03.01.2023	Added Vivado upgrade version description
1.5	28.01.2025	Added AM Mode

Table 1: Revision History

Content

1	INTRODUCTION	8
1.1	Context Overview	8
1.2	Function	9
1.3	Architecture	10
2	IRIG BASICS	11
2.1	Interface	11
2.2	Delays	13
2.3	UTC vs TAI time bases	13
3	REGISTER SET	15
3.1	Register Overview	15
3.2	Register Descriptions	16
3.2.1	General	16
4	DESIGN DESCRIPTION	22
4.1	Top Level - Irig Master	22
4.2	Design Parts	30
4.2.1	TX Processor	30
4.2.2	Registerset	33
4.3	Configuration example	36
4.3.1	Static Configuration	36
4.3.2	AXI Configuration	36
4.4	Clocking and Reset Concept	37
4.4.1	Clocking	37
4.4.2	Reset	37

5	RESOURCE USAGE	39
5.1	Intel/Altera (Cyclone V)	39
5.2	AMD/Xilinx (Artix 7)	39
6	DELIVERY STRUCTURE	40
7	TESTBENCH	41
7.1	Run Testbench	41
8	REFERENCE DESIGNS	42
8.1	Intel/Altera: Terasic SockIt	42
8.2	AMD/Xilinx: Digilent Arty	43
8.3	AMD/Xilinx: Vivado version	44

Definitions

Definitions	
IRIG Master Clock	A clock that can synchronize others to an IRIG output
PI Servo Loop	Proportional-integral servo loop, allows for smooth corrections
Offset	Phase difference between clocks
Drift	Frequency difference between clocks

Table 2: Definitions

Abbreviations

Abbreviations	
AXI	AMBA4 Specification (Stream and Memory Mapped)
BCD	Binary Coded Decimal
PWM	Pulse Width Modulation
DCLS	DC Level Shift
IRQ	Interrupt, Signaling to e.g. a CPU
IRIG	Inter Range Instrumentation Group Timecode
IS	IRIG Slave
TS	Timestamp
TB	Testbench
LUT	Look Up Table
FF	Flip Flop
RAM	Random Access Memory
ROM	Read Only Memory
FPGA	Field Programmable Gate Array
VHDL	Hardware description Language for FPGA's

Table 3: Abbreviations

1 Introduction

1.1 Context Overview

The IRIG Master Clock is meant as a co-processor handling an IRIG output. It takes a time as reference input converts the time in second/nanosecond format to time of day and converts it to the Binary Coded Decimal (BCD) format used by IRIG-B. It aligns the second boundary of the local clock with the reference marker symbol on IRIG and encodes the BCD formatted time into a Pulse Width Modulated (PWM) continuous DCLS data stream taking output delays into account to get the maximum accuracy. Depending it also inserts the Control Bits which are controlled by the user.

The symbol period and pulse widths are aligned with the reference time and varies if corrections are done on the reference so a continuous data stream without interruptions can be guaranteed.

The IRIG Master Clock is designed to work in cooperation with the Counter Clock core from NetTimeLogic (not a requirement). It contains an AXI4Lite slave for configuration and status supervision from a CPU, this is however not required since the IRIG Master Clock can also be configured statically via signals/constants directly from the FPGA.

Optionally the IRIG Master Clock can also handle AC/AM encoded IRIG-B/IRIG-G with an external DAC and a DCLS to AC/AM converter. [Contact us](#) for details

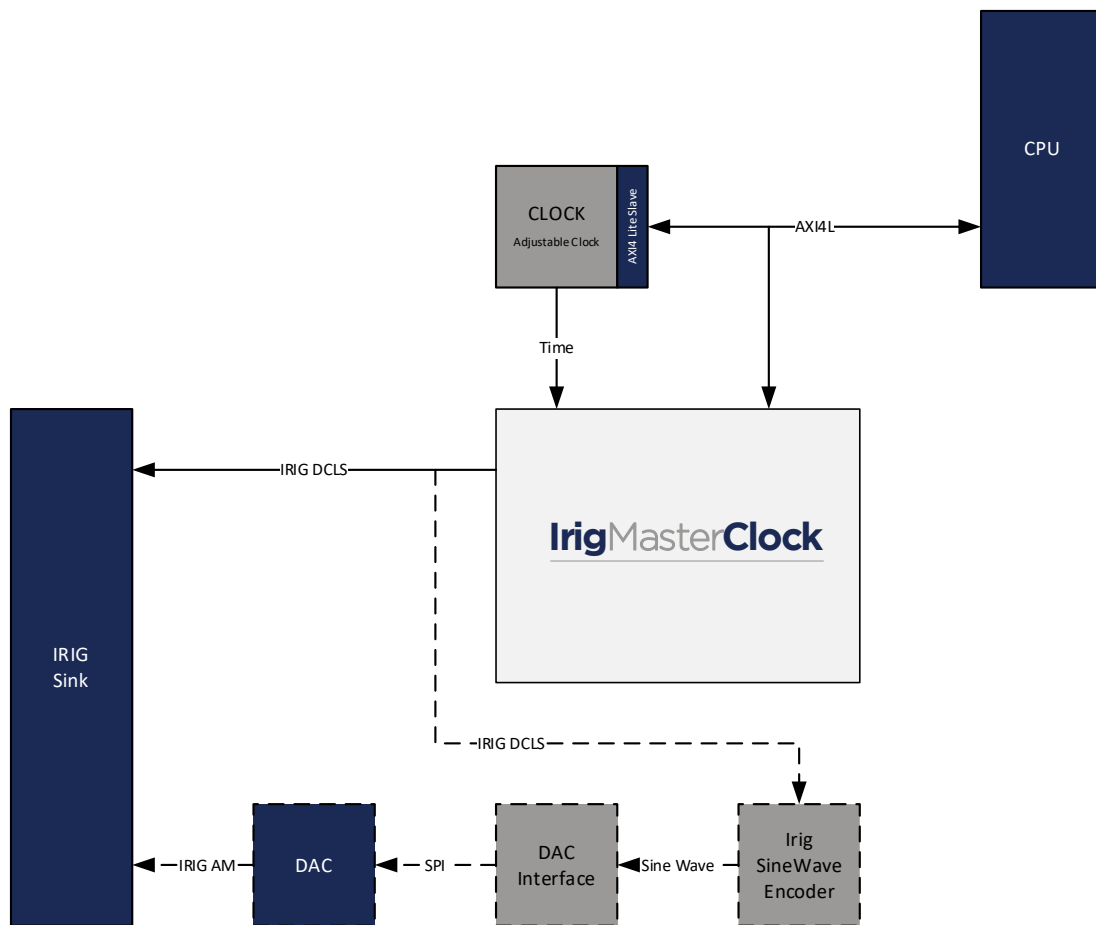

Figure 1: Context Block Diagram

1.2 Function

The IRIG Master Clock generates an IRIG PWM DCLS stream aligned with the local clock, compensating the output delay and taking the correction value between the two time-domains into account. It uses the local clocks frequency for the IRIG encoding to achieve a continuous data stream.

If the reference clock makes a jump in time, the IRIG generation is skipped for the moment of the time jump and restarted at the next second overflow. This can cause that two marker symbols are very close to each other, overlapped or missing, this condition is marked as an error condition and provided to a register.

1.3 Architecture

The core is split up into different functional blocks for reduction of the complexity, modularity and maximum reuse of blocks. The interfaces between the functional blocks are kept as small as possible for easier understanding of the core.

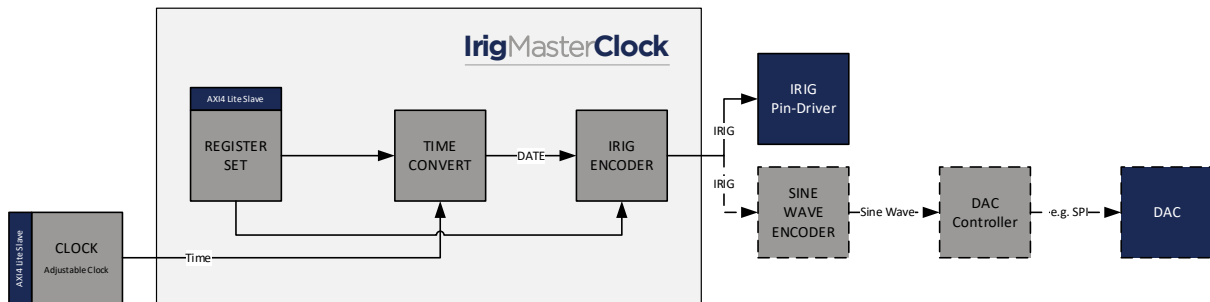

Figure 2: Architecture Block Diagram

Register Set

This block allows reading status values and writing configuration.

Time Converter

This block converts the time from seconds/nanoseconds format to time of day.

IRIG Encoder

This block converts the time of day into Binary Coded Decimal (BCD) and generates the IRIG Pulse Width (PWM) DC Level Shift (DCLS) modulated aligned with the second overflow of the reference time minus the output delay with a configurable duty cycle.

2 IRIG Basics

2.1 Interface

IRIG is a very simple interface and can be either DC Level shift or Amplitude modulated on a base frequency and has Pulse Width modulated symbols. It is a continuous data stream of “One”, “Zero” and “Mark” symbols with symbol patterns to mark the beginning of a time frame. The reference point is the edge to the active level of the reference mark; this shall be at the second overflow of the reference clock. This edge shall be very accurate compared to the other edges of the symbols of a time frame. A time frame can be repeated from multiple times a second to once every multiple second, depending on the IRIG code used. Also the number of bits in a time frame varies from 60 to 100 bits and the time frame content is depending on the IRIG code. This core supports the IRIG-B B007 and IRIG-G G006 code (optionally also the other codes) which generates a time frame of 100 bits once every second.

An IRIG-B time frame in B007/B127 format contains the following:

- Second (BCD encoded)
- Minute (BCD encoded)
- Hour (BCD encoded)
- Day of Year (BCD encoded)
- Year (BCD encoded)
- Seconds of Day (Straight Binary encoded)

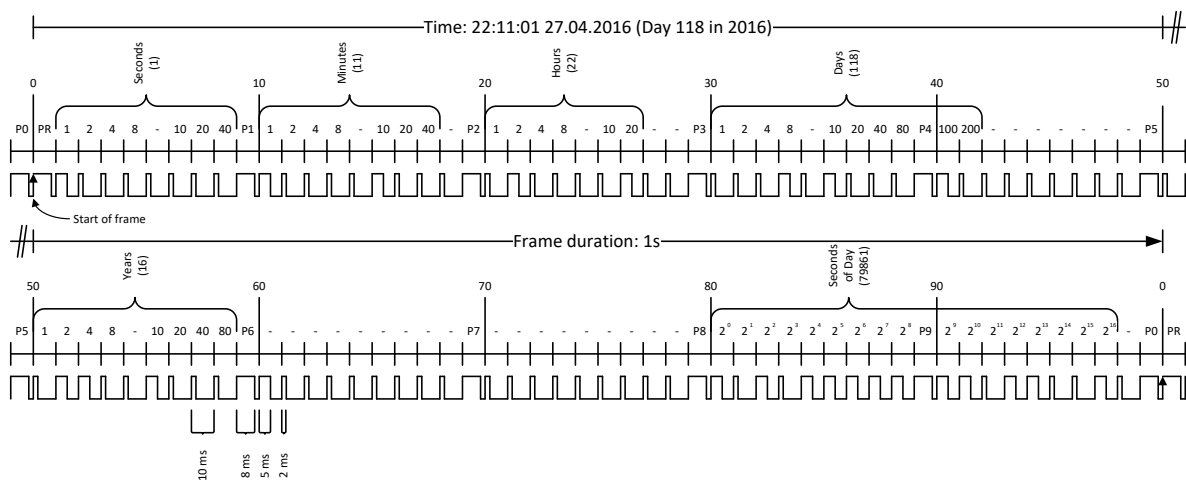

Figure 3: IRIG-B B007/B127 time frame

The B007/B127 format is in principle compatible with B004/B124, B005/B125, B006/B126 and B007/B127 IRIG-B Slaves which only check the time fields.

An IRIG-B time frame in B004/B124 format contains the following:

- Second (BCD encoded)
- Minute (BCD encoded)
- Hour (BCD encoded)
- Day of Year (BCD encoded)
- Year (BCD encoded) (Control Bits 0:8)
- Control Bits 9:17
- Control Bits 18:26
- Seconds of Day (Straight Binary encoded) - unused

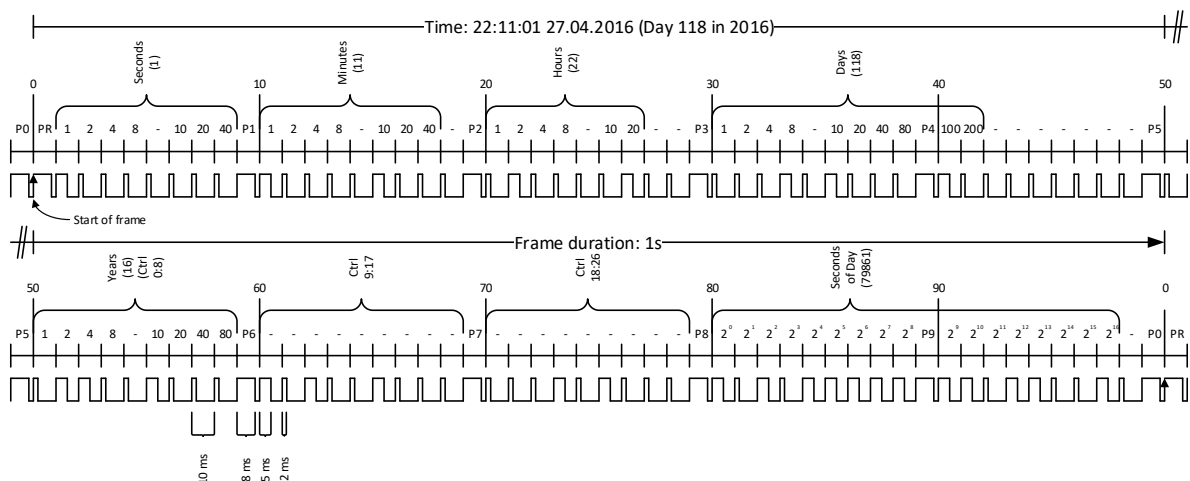

Figure 4: IRIG-B B004/B124 time frame

So, in addition to IRIG-B007/B127 Control Bits are transferred which can be used to send user data or IEEE1344 or C37.118 Information to the Slave.

An IRIG-G time frame in G006/B146 format contains the following:

- Second (BCD encoded)
- Minute (BCD encoded)
- Hour (BCD encoded)
- Day of Year (BCD encoded)
- Year (BCD encoded)
- Milliseconds (BCD encoded)
- Control Bits

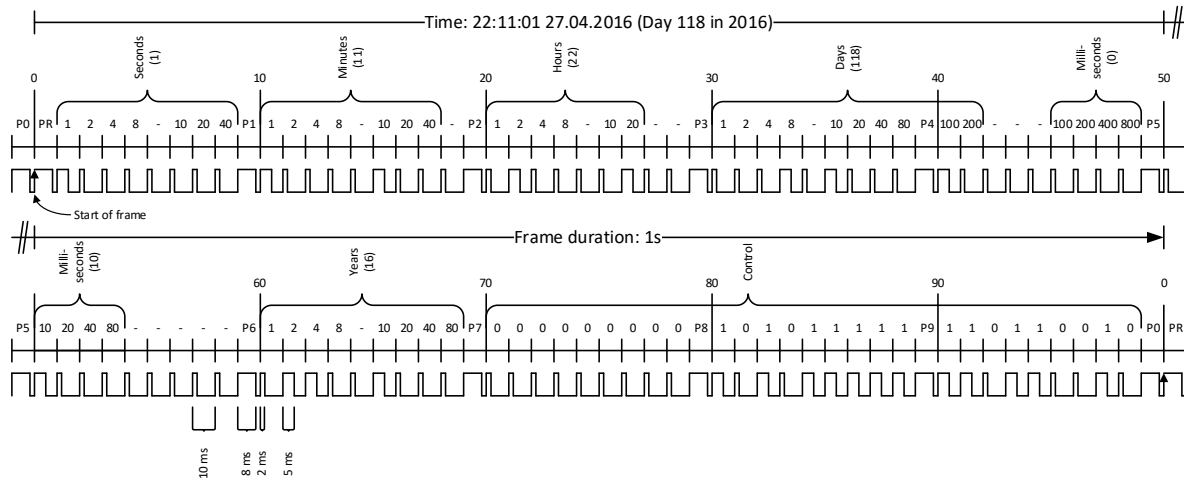

Figure 5: IRIG-G G006/B146 time frame

For high accuracy synchronization delays have to be compensated for.

An IRIG network is normally a one-to-many configuration: one IRIG master synchronizes multiple IRIG slaves of different distance from the master.

2.2 Delays

There are two kinds of delays in an IRIG Network. One is the output delay of the IRIG from the core to the connector; this shall be constant and is compensated for. The second delay is the propagation delay of the signal from the master to the slave. This is dependent on the cable length and medium: 15cm of copper cable are equal to roughly 1ns of propagation delay. As stated earlier in an IRIG network is normally one IRIG master which synchronizes multiple IRIG slaves of different distance from the master. Because the propagation delay to the master is different for each slave this delay has to be compensated for in the slave (supported by NetTimeLogic's IRIG Slave core).

2.3 UTC vs TAI time bases

IRIG time frames contain the time of day on UTC base. UTC has an offset to TAI which is the time base normally used for the Counter Clock. This time offset can be set in the core so the local clock can still run on a TAI base. UTC in comparison to TAI or GPS time has so called leap seconds. A leap second is an additional second which is either added or subtracted from the current time to adjust for the earth rotation variation over time. Until 2016 UTC had additional 36 leap seconds, therefore TAI time is currently 36 seconds ahead of UTC. The issue with UTC time is, that the time makes jumps with the leap seconds which may cause that synchro-

nized nodes go out of sync for a couple of seconds. Leap seconds are normally introduced at midnight of either the 30 of June or 31 of December. For an additional leap second the seconds counter of the UTC time will count to 60 before wrapping around to zero, for one fewer leap second the UTC second counter will wrap directly from 58 to 0 by skipping 59 (this has not happened yet).

Be aware that this core takes no additional precautions to handle leap seconds, so it will make a time jump at a UTC leap second and will lose synchronization since it thinks that it has an offset of one second at tries to readjust this offset. A way to avoid this is to disable the adjustment at the two dates right before midnight (e.g. one minute earlier), wait for the leap second to happen, fetch some time server to get the new offset between TAI and UTC, set this offset to the core and enable the core again. This way the local clock on TAI base makes no jump since the new offset is already taken into account. The only issue with this is that for the time around midnight the clock is free running without a reference.

3 Register Set

This is the register set of the IRIG Master Clock. It is accessible via AXI4Lite Memory Mapped. All registers are 32bit wide, no burst access, no unaligned access, no byte enables, no timeouts are supported. Register address space is not contiguous. Register addresses are only offsets in the memory area where the core is mapped in the AXI inter connects. Non existing register access in the mapped memory area is answered with a slave decoding error.

3.1 Register Overview

Registerset Overview			
Name	Description	Offset	Access
Irig MasterControl Reg	IRIG Master Enable Control Register	0x00000000	RW
Irig MasterStatus Reg	IRIG Master Error Status Register	0x00000004	WC
Irig MasterVersion Reg	IRIG Master Version Register	0x0000000C	RO
Irig MasterCorrection Reg	IRIG Master Second Corrections Register	0x00000010	RW
Irig MasterControlBits Reg	IRIG Master Control Bits Register	0x00000014	RW

Table 4: Register Set Overview

3.2 Register Descriptions

3.2.1 General

3.2.1.1 IRIG Master Control Register

Used for general control over the IRIG Master Clock, all configurations on the core shall only be done when disabled.

IRIG MasterControl Reg																															
Reg Description																															
31	30	29	28	27	26	25	24	23	22	21	20	19	18	17	16	15	14	13	12	11	10	9	8	7	6	5	4	3	2	1	0
						IRIG_MODE								IRIG_CODE																IRIG_AM	ENABLE
Reset: 0x000X0000																															
Offset: 0x0000																															

Name	Description	Bits	Access
-	Reserved, read 0	Bit:31:26	RO
IRIG_MODE	IRIG-B = 1, IRIG-G = 2, others NON	Bit: 25:24	RW
-	Reserved, read 0	Bit:23:19	RO

IRIG_CODE	IRIG-B Code B00X (e.g. 7 = B007/B127) (default by generic)	Bit: 18:16	RW
-	Reserved, read 0	Bit:15:2	RO
IRIG_AM	Use IRIG AM output	Bit: 1	RW
ENABLE	Enable	Bit: 0	RW

3.2.1.2 IRIG Master Status Register

Shows the current status of the IRIG Master Clock.

Irig MasterStatus Reg																															
Reg Description																															
31	30	29	28	27	26	25	24	23	22	21	20	19	18	17	16	15	14	13	12	11	10	9	8	7	6	5	4	3	2	1	0
																											ERROR				
RO																											WC				
Reset: 0x00000000																															
Offset: 0x0004																															

Name	Description	Bits	Access
-	Reserved, read 0	Bit:31:1	RO
ENABLE	Error (sticky)	Bit: 0	WC

3.2.1.3 IRIG Master Version Register

Version of the IP core, even though is seen as a 32bit value, bits 31 down to 24 represent the major, bits 23 down to 16 the minor and bits 15 down to 0 the build numbers.

Irig MasterVersion Reg																															
Reg Description																															
31	30	29	28	27	26	25	24	23	22	21	20	19	18	17	16	15	14	13	12	11	10	9	8	7	6	5	4	3	2	1	0
VERSION																															
RO																															
0XXXXXXXXX																															
Offset: 0x000C																															

Name	Description	Bits	Access
VERSION	Version of the core	Bit: 31:0	RO

3.2.1.4 IRIG Master Correction Register

Correction register to compensate for leap seconds between the different time domains. IRIG is UTC time, all other time in the system is TAI, this leads to a correction of 36 seconds by 2016.

Irig MasterCorrection Reg																															
Reg Description																															
31	30	29	28	27	26	25	24	23	22	21	20	19	18	17	16	15	14	13	12	11	10	9	8	7	6	5	4	3	2	1	0
COR_SIGN																COR_S															
	RW															RW															
Reset: 0x00000000																															
Offset: 0x0010																															

Name	Description	Bits	Access
COR_SIGN	Correction sign	Bit: 31	RW
COR_S	Correction in seconds to the time sent from the IRIG => used to convert between TAI, UTC and GPS (leap seconds)	Bit: 30:0	RW

3.2.1.5 IRIG Master Control Bits Register

Control bits when in IRIG-B000/B001/B004/B005 mode. Representing Bit50-Bit58 & Bit60-Bit68 & Bit70-Bit78 of the IRIG frame: Bit50 => Bit0, Bit78 => Bit26 of the register. When IRIG-B004/B005 is used only Bit60-Bit68 & Bit70-Bit78 are representing the register value, Bit50-Bit58 are representing the year information.

Irig MasterControlBits Reg																															
Reg Description																															
31	30	29	28	27	26	25	24	23	22	21	20	19	18	17	16	15	14	13	12	11	10	9	8	7	6	5	4	3	2	1	0
				CONTROL_BITS																											
RO				RW																											
0x00000000																															
Offset: 0x0014																															

Name	Description	Bits	Access
-	Reserved, read 0	Bit:31:27	RO
CONTROL_BITS	Control bits for IRIG-B000/B001/B004/B005	Bit: 26:0	RW

4 Design Description

The following chapters describe the internals of the IRIG Master Clock: starting with the Top Level, which is a collection of subcores, followed by the description of all subcores.

4.1 Top Level – Irig Master

4.1.1.1 Parameters

The core must be parametrized at synthesis time. There are a couple of parameters which define the final behavior and resource usage of the core.

Name	Type	Size	Description
StaticConfig_Gen	boolean	1	If Static Configuration or AXI is used
IrigSineWaveSupport_Gen	boolean	1	If IRIG AM is supported
IrigBSupport_Gen	boolean	1	If IRIG-B is supported
IrigGSupport_Gen	boolean	1	If IRIG-G is supported
ClockClkPeriodNanosecond_Gen	natural	1	Clock Period in Nanosecond: Default for 50 MHz = 20 ns
OutputDelayNanosecond_Gen	natural	1	Output delay of the IRIG from the output signal to the connector.
DefaultCode_Gen	std_logic_vector	3	Default IRIG-B Code (e.g. "111" => 7 => IRIG-B007)
AxiAddressRangeLow_Gen	std_logic_vector	32	AXI Base Address
AxiAddressRangeHigh_Gen	std_logic_vector	32	AXI Base Address plus Register Size Default plus 0xFFFF
Sim_Gen	boolean	1	If in Testbench simulation mode: true = Simulation, false = Synthesis

Table 5: Parameters

4.1.1.2 Structured Types

4.1.1.2.1 Clk_Time_Type

Defined in Clk_Package.vhd of library ClkLib

Type represents the time used everywhere. For this type overloaded operators + and - with different parameters exist.

Field Name	Type	Size	Description
Second	std_logic_vector	32	Seconds of time
Nanosecond	std_logic_vector	32	Nanoseconds of time
Fraction	std_logic_vector	2	Fraction numerator (mostly not used)
Sign	std_logic	1	Positive or negative time, 1 = negative, 0 = positive.
TimeJump	std_logic	1	Marks when the clock makes a time jump (mostly not used)

Table 6: Clk_Time_Type

4.1.1.2.2 Irig_MasterStaticConfig_Type

Defined in Irig_MasterAddrPackage.vhd of library IrigLib

This is the type used for static configuration.

Field Name	Type	Size	Description
IrigMode	Irig_Mode_Type	3	Define the modes: Unknown_E, IrigB_E, IrigG_E
IrigCode	std_logic_vector	3	IRIG-B Mode: 0=B000, 7=B007
IrigSineWave	std_logic	1	If IRIG AM shall be used
ControlBits	std_logic_vector	27	Control bits to transfer in B000/B001/B004/B005 mode
Correction	Clk_Time_Type	1	Time to correct TAI to UTC or another base.

Table 7: Irig_MasterStaticConfig_Type

4.1.1.2.3 Irig_MasterStaticConfigVal_Type

Defined in Irig_MasterAddrPackage.vhd of library IrigLib

This is the type used for valid flags of the static configuration.

Field Name	Type	Size	Description
Enable_Val	std_logic	1	Enables the IRIG Master

Table 8: Irig_MasterStaticConfigVal_Type

4.1.1.2.4 Irig_MasterStaticStatus_Type

Defined in Irig_MasterAddrPackage.vhd of library IrigLib

This is the type used for static status supervision.

Field Name	Type	Size	Description
CoreInfo	Clk_CoreInfo_Type	1	Info about the Cores state
UtcInfo	Clk_UtcInfo_Typ	1	Info about UTC details
IrigMode	Irig_Mode_Type	3	Which mode it is running: Unknown_E, IrigB_E, IrigG_E
IrigCode	std_logic_vector	3	IRIG-B Mode: 0=B000, 7=B007
IrigSineWave	std_logic	1	If IRIG AM shall be used
IrigCreation	std_logic	1	Core is generating an IRIG signal

Table 9: Irig_MasterStaticStatus_Type

4.1.1.2.5 Irig_MasterStaticStatusVal_Type

Defined in Irig_MasterAddrPackage.vhd of library IrigLib

This is the type used for valid flags of the static status supervision.

Field Name	Type	Size	Description
CoreInfo_Val	std_logic	1	Core Info valid
UtcInfo_Val	std_logic	1	UTC Info valid

Table 10: Irig_MasterStaticStatusVal_Type

4.1.1.3 Entity Block Diagram

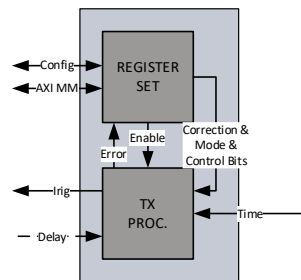

Figure 6: IRIG Master Clock

4.1.1.4 Entity Description

Tx Processor

This module handles the generation of the IRIG signal. It adds the Correction and converts the local clock time in TAI format in seconds since 1.1.1970 without leap seconds into UTC time in time of day format and then into a BCD encoded time and encodes this then to a DCLS encoded continuous PWM signal. It aligns the second boundary exactly to the reference Mark symbol when generating the IRIG data stream. It takes the output delay because of e.g. external driver ICs or Sine Wave generators into account and asserts the internal signal earlier respectively. See 4.2.1 for more details.

Registerset

This module is an AXI4Lite Memory Mapped Slave. It provides access to all registers and allows configuring the IRIG Master Clock. It can be configured to either run in AXI or StaticConfig mode. If in StaticConfig mode, the configuration of the registers is done via signals and can be easily done from within the FPGA without CPU. If in AXI mode, an AXI Master has to configure the registers with AXI writes to the registers, which is typically done by a CPU. See 4.2.2 for more details.

4.1.1.5 Entity Declaration

Name	Dir	Type	Size	Description
Generics				
General				
StaticConfig_Gen	-	boolean	1	If Static Configuration or AXI is used
IrigSineWaveSupport_Gen	-	boolean	1	If IRIG AM is supported
IrigBSupport_Gen	-	boolean	1	If IRIG-B is supported
IrigGSupport_Gen	-	boolean	1	If IRIG-G is supported
ClockClkPeriodNanosecond_Gen	-	natural	1	Integer Clock Period
OutputDelayNanosecond_Gen	-	natural	1	Output delay of the IRIG from the output signal to the connector
DefaultCode_Gen	-	std_logic_vector	3	Default IRIG-B Code
AxiAddressRangeLow_Gen	-	std_logic_vector	32	AXI Base Address
AxiAddressRangeHigh_Gen	-	std_logic_vector	32	AXI Base Address plus Registerset Size
Sim_Gen	-	boolean	1	If in Testbench simulation mode
Ports				
System				
SysClk_ClkIn	in	std_logic	1	System Clock
SysRstN_RstIn	in	std_logic	1	System Reset
Config				
StaticConfig_DatIn	in	Irig_Master StaticConfig_Type	1	Static Configuration
StaticConfig_ValIn	in	Irig_Master StaticConfigVal_Type	1	Static Configuration valid
Status				
StaticStatus_DatOut	out	Irig_Master	1	Static Status

		StaticStatus_Type		
StaticStatus_ValOut	out	Irig_Master StaticStatusVal _Type	1	Static Status valid
Timer				
Timer1ms_EvtIn	in	std_logic	1	Millisecond timer adjusted with the Clock
Time Input				
ClockTime_DatIn	in	Clk_Time_Type	1	Adjusted PTP Clock Time
ClockTime_ValIn	in	std_logic	1	Adjusted PTP Clock Time valid
AXI4 Lite Slave				
AxiWriteAddrValid_ValIn	in	std_logic	1	Write Address Valid
AxiWriteAddrReady_RdyOut	out	std_logic	1	Write Address Ready
AxiWriteAddrAddress_AdrIn	in	std_logic_vector	32	Write Address
AxiWriteAddrProt_DatIn	in	std_logic_vector	3	Write Address Protocol
AxiWriteDataValid_ValIn	in	std_logic	1	Write Data Valid
AxiWriteDataReady_RdyOut	out	std_logic	1	Write Data Ready
AxiWriteDataData_DatIn	in	std_logic_vector	32	Write Data
AxiWriteDataStrobe_DatIn	in	std_logic_vector	4	Write Data Strobe
AxiWriteRespValid_ValOut	out	std_logic	1	Write Response Valid
AxiWriteRespReady_RdyIn	in	std_logic	1	Write Response Ready
AxiWriteRespResponse_DatOut	out	std_logic_vector	2	Write Response
AxiReadAddrValid_ValIn	in	std_logic	1	Read Address Valid
AxiReadAddrReady_RdyOut	out	std_logic	1	Read Address Ready
AxiReadAddrAddress_AdrIn	in	std_logic_vector	32	Read Address
AxiReadAddrProt_DatIn	in	std_logic_vector	3	Read Address Protocol

AxiReadDataValid_ValOut	out	std_logic	1	Read Data Valid
AxiReadDataReady_RdyIn	in	std_logic	1	Read Data Ready
AxiReadDataResponse_DatOut	out	std_logic_vector	2	Read Data
AxiReadDataData_DatOut	out	std_logic_vector	32	Read Data Response
IRIG Output				
Irig_DatOut	out	std_logic	1	IRIG output
IRIG AM Delay Input				
SineWaveDelayNanosecond_DatIn	in	natural	1	Delay of a Sine Wave Encoder

Table 11: IRIG Master Clock

4.2 Design Parts

The IRIG Master Clock core consists of a couple of subcores. Each of the subcores itself consist again of smaller function block. The following chapters describe these subcores and their functionality.

4.2.1 TX Processor

4.2.1.1 Entity Block Diagram

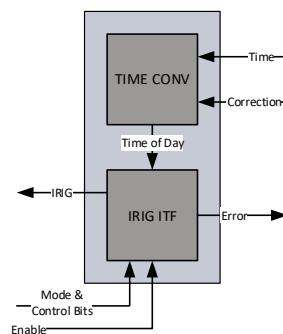

Figure 7: TX Processor

4.2.1.2 Entity Description

IRIG Interface Adapter

This module converts the UTC time in time of day format to a BCD encoded time and encodes this then to a DCLS encoded continuous PWM signal. It aligns the second boundary exactly to the reference Mark symbol when generating the IRIG data stream. It takes the output delay because of e.g. external driver ICs or Sine Wave generators into account and asserts the internal signal earlier respectively. When disabled the IRIG signal will be constantly '0'. If the time makes a time jump it will stop generating the IRIG stream immediately and will pull the IRIG signal to '0', it will continue with generation at the next second boundary.

Time Converter

This module adds the Correction and converts the time from seconds since midnight 1.1.1970 into the Time of Day format: hh:mm:ss ddd:yyyy. It loops over the years and days taking the leap years into account and finally extracts the hours, minutes and seconds. After this conversion, a final correction is done to adjust the second to the next second. Then this time is passed to the IRIG Interface Adapter module.

4.2.1.3 Entity Declaration

Name	Dir	Type	Size	Description
Generics				
General				
ClockClkPeriod Nanosecond_Gen	-	natural	1	Clock Period in Nanosecond
IrigSineWave Support_Gen	-	boolean	1	If IRIG AM is supported
IrigBSupport_Gen	-	boolean	1	If IRIG-B is supported
IrigGSupport_Gen	-	boolean	1	If IRIG-G is supported
TX Processor				
OutputDelay Nanosecond_Gen	-	natural	1	Output delay of the IRIG from the output signal to the connector
Ports				
System				
SysClk_ClkIn	in	std_logic	1	System Clock
SysRstN_RstIn	in	std_logic	1	System Reset
Timer				
Timer1ms_EvtIn	in	std_logic	1	Millisecond timer adjusted with the Clock
Time Input				
ClockTime_DatIn	in	Clk_Time_Type	1	Adjusted PTP Clock Time
ClockTime_ValIn	in	std_logic	1	Adjusted PTP Clock Time valid
IRIG Error Output				
Irig_ErrOut	out	std_logic_vector	1	Indicates a time jump
IRIG Output				
Irig_DatOut	out	std_logic	1	IRIG output
IRIG AM Delay Input				
SineWaveDelay Nanosecond_DatIn	in	natural	1	Delay of a Sine Wave Encoder
IRIG Correction Input				

IrigCorrection_DatIn	in	Clk_Time_Type	1	Additional correction to the transmitted TAI time
IRIG Mode and Control Bits Input				
IrigMode_DatIn	in	Irig_Mode_Type	1	IRIG Mode: Unknown_E, IrigB_E, IrigG_E
IrigCode_DatIn	in	std_logic_vector	3	IRIG-B Code
IrigSineWave_DatIn	in	std_logic	1	IRIG AM
IrigControlBits_DatIn	in	std_logic_vector	27	Control Bits to transfer for IRIG-B000/B001/B004/B005
Enable Input				
Enable_EnalIn	in	std_logic	1	Enables the correction and supervision

Table 12: TX Processor

4.2.2 Registerset

4.2.2.1 Entity Block Diagram

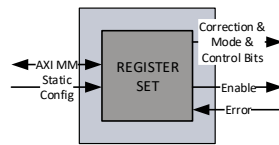

Figure 8: Registerset

4.2.2.2 Entity Description

Register Set

This module is an AXI4Lite Memory Mapped Slave. It provides access to all registers and allows configuring the IRIG Master Clock. AXI4Lite only supports 32 bit wide data access, no byte enables, no burst, no simultaneous read and writes and no unaligned access. It can be configured to either run in AXI or StaticConfig mode. If in StaticConfig mode, the configuration of the registers is done via signals and can be easily done from within the FPGA without CPU. For each parameter a valid signal is available, the enable signal shall be set last (or simultaneously). To change configuration parameters the clock has to be disabled and enabled again (except for IRIG mode and Control Bits). If in AXI mode, an AXI Master has to configure the registers with AXI writes to the registers, which is typically done by a CPU. Parameters can in this case also be changed at runtime.

4.2.2.3 Entity Declaration

Name	Dir	Type	Size	Description
Generics				
Register Set				
StaticConfig_Gen	-	boolean	1	If Static Configuration or AXI is used
IrigBSupport_Gen	-	boolean	1	If IRIG-B is supported
IrigGSupport_Gen	-	boolean	1	If IRIG-G is supported
DefaultCode_Gen	-	std_logic_vector	3	Default IRIG-B Code
AxiAddressRange	-	std_logic_vector	32	AXI Base Address

Low_Gen				
AxiAddressRange High_Gen	-	std_logic_vector	32	AXI Base Address plus Registerset Size
Ports				
System				
SysClk_ClkIn	in	std_logic	1	System Clock
SysRstN_RstIn	in	std_logic	1	System Reset
Config				
StaticConfig_DatIn	in	Irig_Master StaticConfig_Type	1	Static Configuration
StaticConfig_ValIn	in	Irig_Master StaticConfigVal _Type	1	Static Configuration valid
Status				
StaticStatus_DatOut	out	Irig_Master StaticStatus_Type	1	Static Status
StaticStatus_ValOut	out	Irig_Master StaticStatusVal _Type	1	Static Status valid
AXI4 Lite Slave				
AxiWriteAddrValid _ValIn	in	std_logic	1	Write Address Valid
AxiWriteAddrReady _RdyOut	out	std_logic	1	Write Address Ready
AxiWriteAddrAddress _AdrIn	in	std_logic_vector	32	Write Address
AxiWriteAddrProt _DatIn	in	std_logic_vector	3	Write Address Protocol
AxiWriteDataValid _ValIn	in	std_logic	1	Write Data Valid
AxiWriteDataReady _RdyOut	out	std_logic	1	Write Data Ready
AxiWriteDataData _DatIn	in	std_logic_vector	32	Write Data
AxiWriteDataStrobe _DatIn	in	std_logic_vector	4	Write Data Strobe
AxiWriteRespValid _ValOut	out	std_logic	1	Write Response Valid
AxiWriteRespReady _RdyIn	in	std_logic	1	Write Response Ready
AxiWriteResp Response_DatOut	out	std_logic_vector	2	Write Response

AxiReadAddrValid_ValIn	in	std_logic	1	Read Address Valid
AxiReadAddrReady_RdyOut	out	std_logic	1	Read Address Ready
AxiReadAddrAddress_AdrIn	in	std_logic_vector	32	Read Address
AxiReadAddrProt_DatIn	in	std_logic_vector	3	Read Address Protocol
AxiReadDataValid_ValOut	out	std_logic	1	Read Data Valid
AxiReadDataReady_RdyIn	in	std_logic	1	Read Data Ready
AxiReadDataResponse_DatOut	out	std_logic_vector	2	Read Data
AxiReadDataData_DatOut	out	std_logic_vector	32	Read Data Response
IRIG Error Input				
Irig_ErrIn	in	std_logic_vector	1	Indicates a time jump or other Error conditions
IRIG Correction Output				
IrigCorrection_DatOut	out	Clk_Time_Type	1	Additional correction to the transmitted TAI time
IRIG Mode and Control Bits Output				
IrigMode_DatOut	out	Irig_Mode_Type	1	IRIG Mode: Unknown_E, IrigB_E, IrigG_E
IrigCode_DatOut	out	std_logic_vector	3	IRIG-B Code
IrigSineWave_DatOut	out	std_logic	1	IRIG AM
IrigControlBits_DatOut	out	std_logic_vector	27	Control Bits to transfer for IRIG-B000/B001/B004/B005
Enable Output				
IrigMasterEnable_DatOut	out	std_logic	1	Enables the correction and supervision

Table 13: Registerset

4.3 Configuration example

In both cases the enabling of the core shall be done last, after or together with the configuration.

4.3.1 Static Configuration

```
constant IrigStaticConfigMaster_Con : Irig_MasterStaticConfig_Type := (  
  IrigMode           => IrigB_E, -- IRIG-B  
  IrigCode           => std_logic_vector(to_unsigned(7, 3)), -- IRIG-B007  
  IrigSineWave       => '0', -- DCLS  
  ControlBits        => (others => '0'), -- not used in IRIGB-007  
  Correction         => (  
    Second           => x"00000024", -- UTC 36 leap seconds  
    Nanosecond       => (others => '0'), -- no nanoseconds  
    Fraction         => (others => '0'), -- no fractions  
    Sign             => '1', -- UTC correct in negative  
    TimeJump        => '0')  
  );  
  
constant IrigStaticConfigValMaster_Con : Irig_MasterStaticConfigVal_Type := (  
  Enable_Val        => '1'  
  );
```

Figure 9: Static Configuration

The pulse width can be changed at runtime. It is always valid.

4.3.2 AXI Configuration

The following code is a simplified pseudocode from the testbench: The base address of the IRIG Master Clock is 0x10000000.

```
-- IRIG MASTER  
-- Config  
-- correction of minus 36 second to convert TAI to UTC  
AXI WRITE 10000010 80000024  
-- enable IRIG Master in B007 mode  
AXI WRITE 10000000 01070001
```

Figure 10: AXI Configuration

In the example the Correction is first set to minus 36 seconds then the core is enabled.

4.4 Clocking and Reset Concept

4.4.1 Clocking

To keep the design as robust and simple as possible, the whole IRIG Master Clock, including the Counter Clock and all other cores from NetTimeLogic are run in one clock domain. This is considered to be the system clock. Per default this clock is 50MHz. Where possible also the interfaces are run synchronous to this clock. For clock domain crossing asynchronous fifos with gray counters or message patterns with meta-stability flip-flops are used. Clock domain crossings for the AXI interface is moved from the AXI slave to the AXI interconnect.

Clock	Frequency	Description
System		
System Clock	50MHz (Default)	System clock where the IRIG Master runs on as well as the counter clock etc.
IRIG Interface		
IRIG	100 Hz	No clock, asynchronous data signal.
AXI Interface		
AXI Clock	50MHz (Default)	Internal AXI bus clock, same as the system clock

Table 14: Clocks

4.4.2 Reset

In connection with the clocks, there is a reset signal for each clock domain. All resets are active low. All resets can be asynchronously set and shall be synchronously released with the corresponding clock domain. All resets shall be asserted for the first couple (around 8) clock cycles. All resets shall be set simultaneously and released simultaneously to avoid overflow conditions in the core. See the reference designs top file for an example of how the reset shall be handled.

Reset	Polarity	Description
System		
System Reset	Active low	Asynchronous set, synchronous release with the system clock
AXI Interface		

AXI Reset	Active low	Asynchronous set, synchronous release with the AXI clock, which is the same as the system clock
-----------	------------	---

Table 15: Resets

5 Resource Usage

Since the FPGA Architecture between vendors and FPGA families differ there is a split up into the two major FPGA vendors.

5.1 Intel/Altera (Cyclone V)

Configuration	FFs	LUTs	BRAMs	DSPs
Minimal (Static configuration and only IRIG-B)	599	2087	0	0
Maximal (AXI configuration and IRIG-B and IRIG-G)	695	2672	0	0

Table 16: Resource Usage Intel/Altera

5.2 AMD/Xilinx (Artix 7)

Configuration	FFs	LUTs	BRAMs	DSPs
Minimal (Static configuration and only IRIG-B)	527	1666	0	0
Maximal (AXI configuration and IRIG-B and IRIG-G)	613	2029	0	0

Table 17: Resource Usage AMD/Xilinx

6 Delivery Structure

```
AXI -- AXI library folder
|-Library -- AXI library component sources
|-Package -- AXI library package sources

CLK -- CLK library folder
|-Library -- CLK library component sources
|-Package -- CLK library package sources

COMMON -- COMMON library folder
|-Library -- COMMON library component sources
|-Package -- COMMON library package sources

IRIG -- IRIG library folder
|-Core -- IRIG library cores
|-Doc -- IRIG library cores documentations
|-Library -- IRIG library component sources
|-Package -- IRIG library package sources
|-Refdesign -- IRIG library cores reference designs
|-Testbench -- IRIG library cores testbench sources and sim/log

SIM -- SIM library folder
|-Doc -- SIM library command documentation
|-Package -- SIM library package sources
|-Testbench -- SIM library testbench template sources
|-Tools -- SIM simulation tools
```

7 Testbench

The Irig Master testbench consist of 2 parse/port types: AXI and IRIG.

The IRIG RX port takes the time of the Clock instance as reference and the IRIG stream from the DUT port. The IRIG RX port checks the waveform if the stream is encoded correctly and if the second boundary is asserted at the correct point in time. In addition, for configuration and result checks an AXI read and write port is used in the testbench and for accessing more than one AXI slave also an AXI interconnect is required.

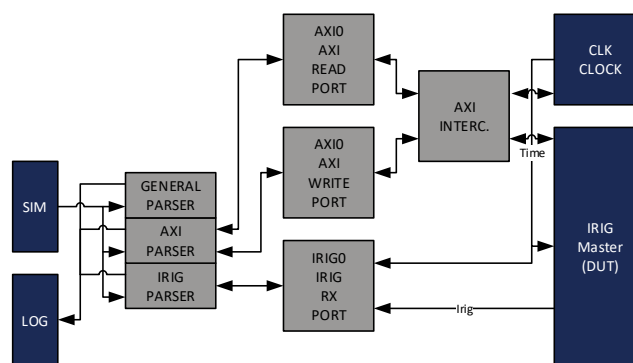

Figure 11: Testbench Framework

For more information on the testbench framework check the Sim_ReferenceManual documentation.

With the Sim parameter set the time base for timeouts are divided by 1000 to 100000 to speed up simulation time.

7.1 Run Testbench

1. Run the general script first

```
source XXX/SIM/Tools/source_with_args.tcl
```

2. Start the testbench with all test cases

```
src XXX/IRIG/Testbench/Core/IrigMaster/Script/run_Irig_Master_Tb.tcl
```

3. Check the log file LogFile1.txt in the XXX/IRIG/Testbench/Core/IrigMaster/Log/ folder for simulation results.

8 Reference Designs

The IRIG Master reference design contains a PLL to generate all necessary clocks (cores are run at 50 MHz), an instance of the IRIG Master Clock IP core and an instance of the Adjustable Counter Clock IP core (needs to be purchased separately). Optionally it also contains an instance of an PPS Master Clock IP core (has to be purchased separately). To instantiate the optional IP core, change the corresponding generic (PpsMasterAvailable_Gen) to true via the tool specific wizards.

The Reference Design is intended to be connected to any IRIG Slave which can handle a logic high single ended IRIG signal. The PPS Master Clock is used to create a PPS output which is compensated for the output delay and has a configurable duty cycle, if not available an uncompensated PPS is directly generated out of the MSB of the Time.

All generics can be adapted to the specific needs.

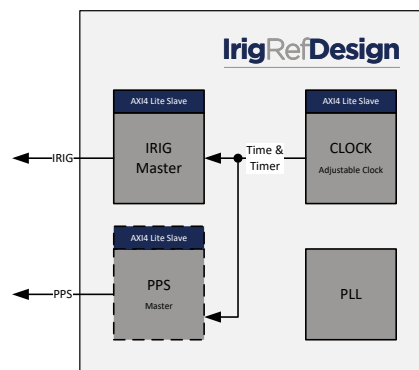

Figure 12: Reference Design

8.1 Intel/Altera: Terasic SocKit

The SocKit board is an FPGA board from Terasic Inc. with a Cyclone V SoC FPGA from Intel/Altera. (<http://www.terasic.com.tw/cgi-bin/page/archive.pl?Language=English&CategoryNo=205&No=816>)

1. Open Quartus 16.x
2. Open Project /IRIG/Refdesign/Altera/SocKit/IrigMaster/IrigMaster.qpf
3. If the optional core PPS Master Clock is available add the files from the corresponding folders (PPS/Core, PPS/Library and PPS/Package)
4. Change the generics (PpsMasterAvailable_Gen) in Quartus (in the settings menu, not in VHDL) to true for the optional cores that are available.
5. Rerun implementation

6. Download to FPGA via JTAG

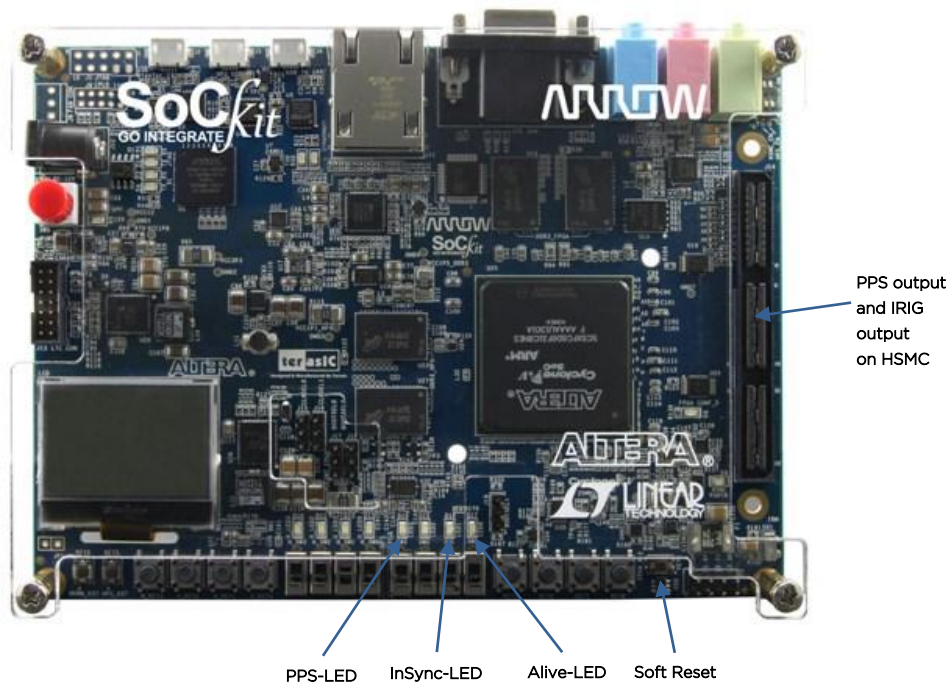

Figure 13: SoCkit (source Terasic Inc)

For the ports on the HSMC connector the GPIO to HSMC adapter from Terasic Inc. was used.

8.2 AMD/Xilinx: Digilent Arty

The Arty board is an FPGA board from Digilent Inc. with an Artix7 FPGA from AMD/Xilinx. (<http://store.digilentinc.com/artix-7-fpga-development-board-for-makers-and-hobbyists/>)

1. Open Vivado 2019.1.
Note: If a different Vivado version is used, see chapter 8.3.
2. Run TCL script /IRIG/Refdesign/Xilinx/Arty/IrigMaster/IrigMaster.tcl
 - a. This has to be run only the first time and will create a new Vivado Project
3. If the project has been created before open the project and do not rerun the project TCL

4. If the optional core PPS Master Clock is available add the files from the corresponding folders (PPS/Core, PPS/Library and PPS/Package) to the corresponding Library (PpsLib).
5. Change the generics (PpsMasterAvailable_Gen) in Vivado (in the settings menu, not in VHDL) to true for the optional cores that are available.
6. Rerun implementation
7. Download to FPGA via JTAG

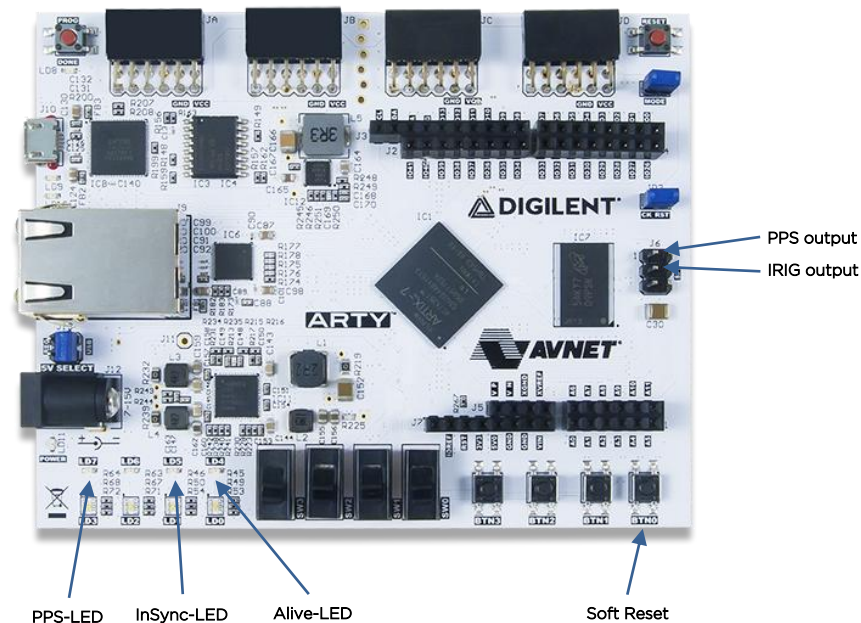

Figure 14:
(source Digilent Inc)

Arty

8.3 AMD/Xilinx: Vivado version

The provided TCL script for creation of the reference-design project is targeting AMD/Xilinx Vivado 2019.1.

If a lower Vivado version is used, it is recommended to upgrade to Vivado 2019.1 or higher.

If a higher Vivado version is used, the following steps are recommended:

- Before executing the project creation TCL script, the script's references of Vivado 2019 should be manually replaced to the current Vivado version. For example, if version Vivado 2022 is used, then:
 - The statement occurrences:

```
set_property flow "Vivado Synthesis 2019" $obj
```

shall be replaced by:

```
set_property flow "Vivado Synthesis 2022" $obj
```

- The statement occurrences:

```
set_property flow "Vivado Implementation 2019" $obj
```

shall be replaced by:

```
set_property flow "Vivado Implementation 2022" $obj
```

- After executing the project creation TCL script, the AMD/Xilinx IP cores, such as the Clocking Wizard core, might be locked and a version upgrade might be required. To do so:
 1. At "Reports" menu, select "Report IP Status".
 2. At the opened "IP Status" window, select "Upgrade Selected". The tool will upgrade the version of the selected IP cores.

A List of tables

Table 1:	Revision History.....	4
Table 2:	Definitions.....	7
Table 3:	Abbreviations	7
Table 4:	Register Set Overview	15
Table 5:	Parameters.....	22
Table 6:	Clk_Time_Type	23
Table 7:	Irig_MasterStaticConfig_Type	23
Table 8:	Irig_MasterStaticConfigVal_Type.....	24
Table 9:	Irig_MasterStaticStatus_Type.....	24
Table 10:	Irig_MasterStaticStatusVal_Type	24
Table 11:	IRIG Master Clock	29
Table 12:	TX Processor.....	32
Table 13:	Registerset	35
Table 14:	Clocks	37
Table 15:	Resets	38
Table 16:	Resource Usage Intel/Altera.....	39
Table 17:	Resource Usage AMD/Xilinx.....	39

B List of figures

Figure 1:	Context Block Diagram	9
Figure 2:	Architecture Block Diagram.....	10
Figure 3:	IRIG-B B007/B127 time frame.....	11
Figure 4:	IRIG-B B004/B124 time frame	12
Figure 5:	IRIG-G G006/B146 time frame	13
Figure 6:	IRIG Master Clock	26
Figure 7:	TX Processor.....	30
Figure 8:	Registerset	33
Figure 9:	Static Configuration	36
Figure 10:	AXI Configuration	36
Figure 11:	Testbench Framework	41
Figure 12:	Reference Design.....	42
Figure 13:	SockKit (source Terasic Inc).....	43
Figure 14:	Arty (source Digilent Inc)	44